

smartmi

Smartmi Humidifier Rainforest

User Manual

WARNING

- This appliance is not intended for use by persons (including children) with reduced physical, sensory or mental capabilities, or lack of experience and knowledge, unless they have been given supervision or instruction concerning use of the appliance by a person responsible for their safety.
- Children shall not play with the appliance.
- Cleaning and user maintenance shall not be made by children without supervision.
- Keep the appliance out of the reach of children. Steam and boiling water may cause burns.
- Be aware that high humidity levels may encourage the growth of biological organisms in the environment.
- Do not permit the area around the humidifier to become damp or wet. If dampness occurs, turn the output of the humidifier down. If the humidifier output volume cannot be turned down, use the humidifier intermittently. Do not allow absorbent materials, such as carpeting, curtains, drapes, or tablecloths, to become damp.
- Unplug the appliance during filling and cleaning.
- Never leave water in the reservoir when the appliance is not in use.

- Empty and clean the humidifier before storage. Clean the humidifier before next use.
- To prevent electric shocks, fire, personal injury and other damage, do not use the humidifier when:
 - The main body of the humidifier is tilted. Tilting the humidifier may cause the water level to be reported incorrectly or the water to overflow. The humidifier should be placed on a flat and stable surface while in use.
 - There are nearby objects that may fall or are unstable.
 - In hot, humid or wet places such as bathrooms.
- Power the humidifier using the standard adapter supplied with the humidifier. Due to safety considerations, damaged adapters or power cords must be replaced by the manufacturer or a professional from a designated repair service provider.
- For Use Only With Zhongshan Baolijin Electronic Co.,Ltd. BLJ9W120075P-VA Charger.
- Do not disassemble the product yourself unless disassembly is required for maintenance. For repair information, contact Smartmi Customer Service.

Product Description

Package List: Unit, Water Tank, Adapter, User Manual

Read this manual carefully before use, and retain it for future reference.

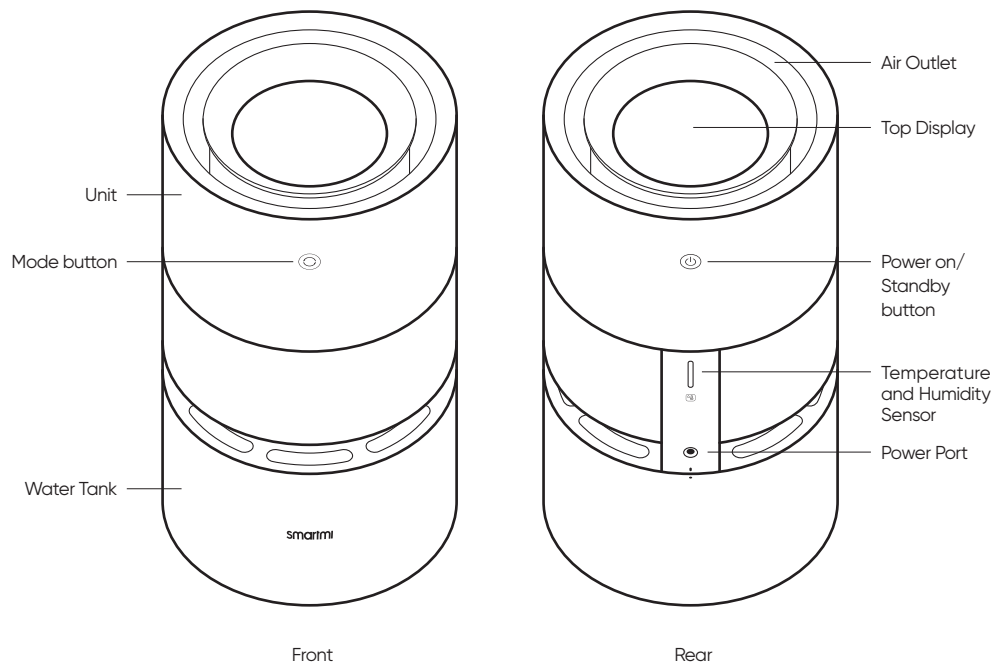

Note: In this manual, the illustrations of the product and its accessories and the user interface are schematic diagrams for reference only. The actual product may vary from that shown in the schematic diagrams due to product updates and upgrades. Please refer to the actual product.

Display Description

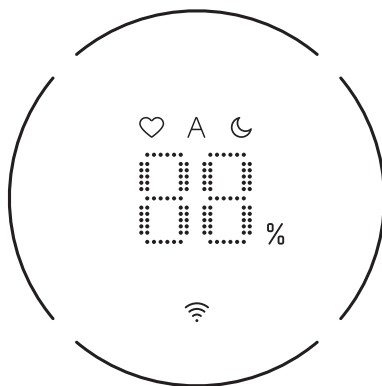

Ambient Humidity Display



Gear Mode

- Max:** The device is operating in maximum humidification mode.
- Automatic:** the rotation speed is automatically set based on the current humidity
- Sleep:** Ultra-low noise operation



Wi-Fi Indicator



Water Level Ring Indicator

Low Water Level

When the device detects a low water level (tank water level <15%), the Water Level Ring Indicator blinks red.

Display of Real-time Water Level

When the humidification page is displayed, the ring indicator indicates the real-time water level.

- 15%-25%
- 25%-50%
- 50%-75%
- 75%-100%

Use

Installation

Bring the unit and water tank points into alignment and install the unit as shown in the picture. Plug in the power adapter to power on the device.

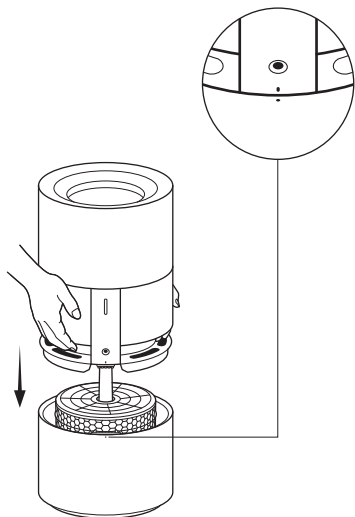

Power on/Standby

Press the Power on/Standby button on the back of the unit to power the device on/switch to Standby mode.

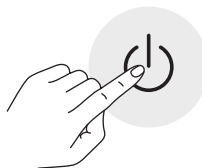

Filling the Device

Pure water is recommended to avoid scaling.

Fill the water tank up to the high water level (the MAX line) as shown in the picture on the right.

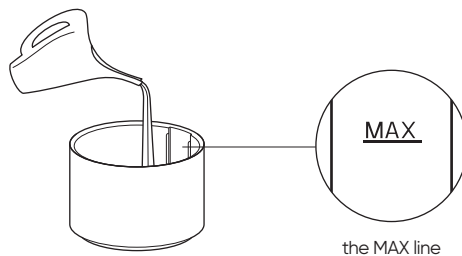

Tip: Keep the unit upright.

Use

Linking the Device to Smartmi Link

This product has been linked to the Smartmi Link and can be controlled using the app.

Scan the QR code or search for "Smartmi Link" on the app store to download and install the app. Go to the app's homepage, click "+" in the middle of the page, then add the device as prompted.



Note:

- Please ensure that your Wi-Fi network is both available and has Internet access. Place your phone as close to this product as possible. (This product does not support 5G networks)
- This product will be listed as "Smartmi Humidifier Rainforest" in the app's device listing.

When the device reaches the set target humidity, it will continue to humidify until reaching 3% above the designated target value and activating the standby mode. In standby mode, it will resume when the humidity drops to 3% below the target value.

Intelligent Control with Apple HomeKit

- 01 Open the Home app on your iPhone/iPad.
- 02 Tap "Add Accessory" and then scan the HomeKit setup code on the product sticker (two stickers on the device unit, see illustration), or enter the eight-digit setup code above the HomeKit Setup Code. The device will then be linked to the Apple Home app.

The device can be linked to Smartmi Link after linking to HomeKit. Go to the Personal Info page on Smartmi Link. Tap "HomeKit Info" and then link the HomeKit device as prompted. Devices linked to Smartmi Link can also be added to HomeKit. Go to the Device Control page on Smartmi Link. Tap "Add to HomeKit" in "Settings" and then link the device to HomeKit as prompted.

Note:

- Please ensure that your Wi-Fi network is both available and has Internet access. Place your phone as close to this product as possible. (This product does not support 5G networks).
- To control this accessory which is compatible with HomeKit, it is recommended to use iOS 13.0 or a later version.
- Please keep the HomeKit setup code, as you will need to scan the code to link the device to HomeKit after a factory reset.
- iPad and iPhone are trademarks of Apple Inc., registered in the U.S. and other countries.
- Controlling this HomeKit-enabled accessory automatically and away from home requires a HomePod, Apple TV, or iPad set up as a home hub. It is recommended that you update to the latest software and operating system.

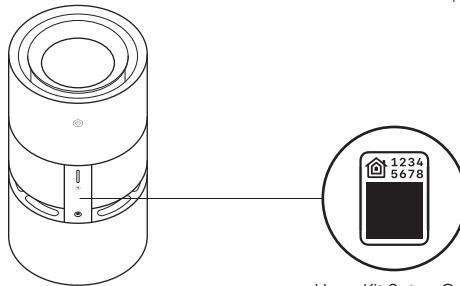

HomeKit Setup Code

* If you need more detailed instruction, please visit: <https://www.smartmiglobal.com/pages/helpcenter>

Use

Switching Between Modes

While the device is turned on, press the Mode button on the front of the device to switch between three modes in sequence (Max - Automatic - Sleep).

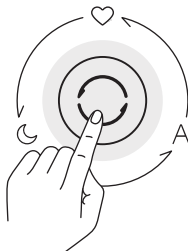

Wi-Fi Resetting

When you connect the App for the first time or fail to connect, press and hold the Mode button for seven seconds. The Wi-Fi icon will blink and the device will issue a notification tone signifying that the device is ready to be connected and the Wi-Fi has been reset.

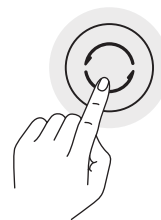

Enabling/Disabling Wi-Fi

Tap and hold the power on/standby button and mode button for 7 seconds. The humidifier will make a notification sound and the Wi-Fi will be disabled. While the Wi-Fi is disabled, tap and hold the power on/standby button and mode button for 7 seconds. The humidifier will make a notification sound and the Wi-Fi will be enabled.

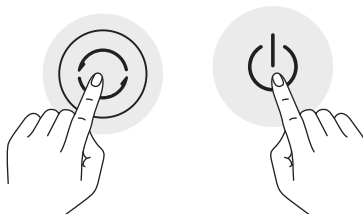

Self-cleaning Mode

Use the app to enable or disable self-cleaning mode. After the self-cleaning task is completed, the device will issue a notification tone, switch to Standby mode, and darken the screen.

Filter Replacement

Warning: Before replacing the filter, ensure that the device has been turned off and unplugged.

Note: To avoid injury, avoid placing your fingers in between the unit and the water tank when replacing the filter. Keep the unit upright.

01 Remove the unit

Remove the unit by pulling it up.

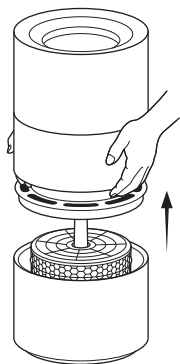

02 Take out the used filter and install a new one.

Take out the used filter, install a new one face up.

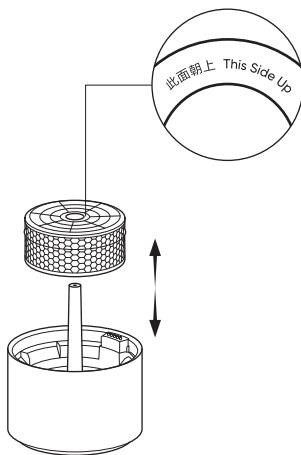

03 Install the Unit

Bring the unit and water tank points into alignment and install the unit.

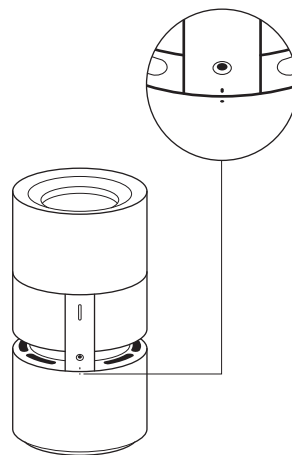

Where can I buy a filter

Scan the QR code or visit Smartmi's official shopping mall <https://smartmiglobal.com/products/smartmi-humidifier-rainforest-filter> for more information.

Tips:

- It is recommended that the filter be replaced every six months to a year.
- Please buy genuine compatible filters from official channels only.

Maintenance and Care

Warning: Be sure to turn off and unplug the device before performing the following operations. Keep the unit upright when cleaning the device.

Cleaning the Device

A reasonable amount of food-grade citric acid detergent is recommended for cleaning and removing sediment from the water tank, the transparent window, and the filter. In general, it is recommended that you allow the max mode to run for approximately 15 minutes (though this can be shortened or lengthened depending on the actual conditions). Rinse the water tank, water collector, and filter with clean water once you have finished.

Notes:

- To avoid damaging the device during the cleaning process, ensure that the temperature of the water used to clean the device does not exceed 35°C.
- To avoid damaging the device, do not use detergents that are highly acidic or alkali-based or other highly corrosive cleaning solutions.

Cleaning the Transparent Window

Remove the unit and place it on a horizontal table. While holding the device with one hand, use your other hand to wipe the inner wall of the transparent window gently with a soft cloth.

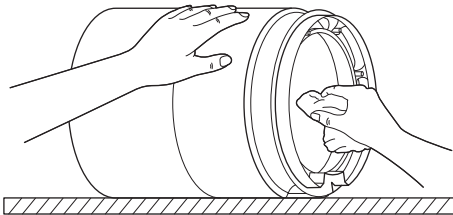

Note: Rinsing the unit is prohibited. Before wiping the unit, wring out the soft cloth thoroughly to avoid damaging from excess water.

Cleaning the Pump

After removing the unit and the filter, take out the water collector from the water tank and turn it over. Brush the pump gently with a soft brush.

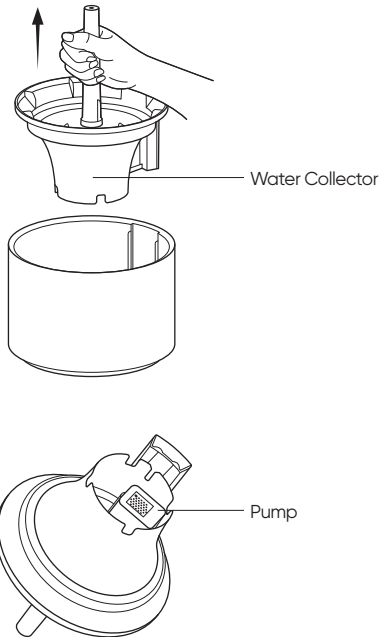

Maintenance and Care

Cleaning the Water Tank

To prevent the water tank from becoming contaminated and producing an unpleasant odor, rinse the water tank with clean water or wipe it with a soft cloth to keep it clean.

There are drainage holes at the bottom of the water tank. Do not use the water tank straight away after it has been fully rinsed or after adding too much water by accident. Instead, place the water tank on the ground with the drainage holes facing down to drain the water from inside the tank.

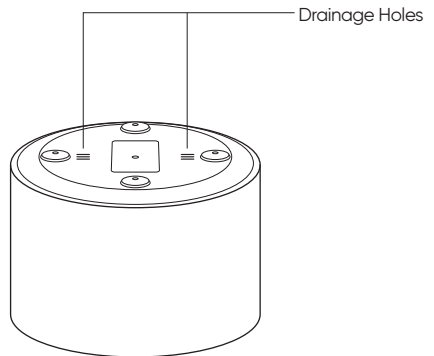
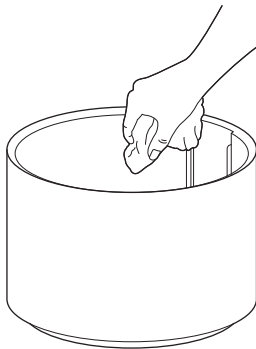

Note: It is recommended that the water tank be cleaned once a week or as required by the frequency of use.

Notes

Moving

- Always turn the humidifier off and unplug it before moving it.
- Before handling or moving the humidifier, drain any remaining water from the water tank.

Assembling

- Follow the instructions to install the humidifier correctly to prevent electric shocks, fire, personal injury, and other damage.
- Do not turn the humidifier on before it is fully assembled.

Adapter

Follow the instructions below when using the adapter to prevent electric shocks, fire, or damage:

- Connect the adapter plug to an appropriate outlet.
- Do not pinch, bend, or twist the adapter cord excessively. Otherwise, the wire inside may be broken or exposed.
- Unplug the humidifier before servicing or moving the humidifier.
- Use the standard adapter supplied to power the humidifier. Due to safety considerations, damaged adapters or power cords must be replaced by the manufacturer or a professional from a designated repair service provider.

In Use

- If the humidifier generates abnormal noises, produces odors or becomes hot, turn it off immediately.
- Do not put fingers or foreign objects into safety parts, movable parts, air inlets or outlets.
- Do not let objects such as hair or fabric come near the main unit, as these objects may get caught in or block the air inlets and outlets.
- Do not lean on or tilt the humidifier while in use.
- Ensure sufficient ventilation when using the humidifier at the same time as household gas appliances (such as gas stoves and gas water heaters) to prevent carbon monoxide poisoning. Pure water is recommended for the humidifier.
- Depending on the water quality, tap water may cause scale buildup on the pump, filter, inner wall of the water tank, and the transparent window. Scale buildup will affect the normal operation of the humidifier, in which case the humidifier will need to be cleaned as per the instructions in the Maintenance and Care section.

Storage and transportation

- Before long-term storage, make sure that

the water tank and the evaporative tank of the humidifier are completely dry, then put the humidifier assembled for storage in a cool dry place.

- The device should be placed away from heat sources and out of direct sunlight.
- Do not transport at extreme temperatures.

Warnings

- To avoid damaging the humidifier, do not add water of more than 35°C to the water tank.
- Unplug the humidifier before adding water or cleaning.
- The water tank MAX indicates the level beyond which no more water should be added.

Basic Specifications

Product Name	Smartmi Humidifier Rainforest
Model	CJJSQ06ZM
Operating Principle	Flow-through Spray-style Evaporation
Dimensions	Φ220 × 422mm
Net Weight	Approx. 3.3 kg
Rated Input of Adapter	100~240V~, 50/60Hz, 0.3A
Rated Voltage	12V ~
Rated Power	7W
Noise	≤50dB(A)
Rated Humidifying Capacity	200mL/h
Rated Water Tank Capacity	3L
Wireless Connection	Wi-Fi IEEE802.11b/g/n 2.4GHz

Operating Temperature: 10 ~ 40 °C; Humidity: relative humidity no greater than 80% (at 25 °C)

RF Specification:

Wi-Fi 2.4G (2400 - 2483.5 MHz), Max. RF Output Power: <20 dBm
Under normal use of condition, this equipment should be kept a separation distance of at least 20cm between the antenna and the body of the user

Note:

- Noise is measured in a laboratory environment.
- The date of manufacture is indicated on the equipment.

Power Adapter

Information Published	Value and Precision	Unit
Manufacturer	Zhongshan Baolijin Electronic Co.Ltd.	-
Model Identifier	BLJ9W120075P-VA	-
Input Voltage	100-240	V~
Input AC Frequency	50/60	Hz
Output Volatage	12.0	V~
Output Current	0.75	A
Output Power	9.0	W
Average Active Efficiency	83.81	%
Efficiency at Low Load(10%)	75.21	%
No-load Power Consumption	0.072	W

Regulatory Compliance Information

Europe – EU declaration of conformity

CE Hereby, Beijing Smartmi Electronic Technology Co., Ltd. declares that the radio equipment – Smartmi Humidifier Rainforest, type CJJSQ06ZM is in compliance with Directive 2014/53/EU. The full text of the EU declaration of conformity is available at the following internet address: <https://www.smartmiglobal.com/doc.html>

Disposal and recycling information



All products bearing this symbol are waste electrical and electronic equipment (WEEE as in directive 2012/19/EU) which should not be mixed with unsorted household waste. Instead, you should protect human health and the environment by handing over your waste equipment to a designated collection point for the recycling of waste electrical and electronic equipment, appointed by the government or local authorities. Correct disposal and recycling will help prevent potential negative consequences to the environment and human health. Please contact the installer or local authorities for more information about the location as well as terms and conditions of such collection points.



Manufactured by: Beijing Smartmi Electronic Technology Co., Ltd.
Address: Room 6111, 1st Floor, Building 6, No.18 Xueqing Road, Haidian District, Beijing, China

For detailed e-manual, please go to <https://www.smartmiglobal.com/pages/manual>
For more information, please visit: <https://www.smartmiglobal.com/>

www.smartmiglobal.com